

53-1002119-01
May 2014



FIPS Security Seal

**Procedures for Brocade FCX Series and
Brocade FastIron SX Series**

BROCADE

53-1002119-01

© 2014, Brocade Communications Systems, Inc. All Rights Reserved.

Brocade, the B-wing symbol, Brocade Assurance, ADX, AnyIO, DCX, Fabric OS, FastIron, HyperEdge, ICX, MLX, MyBrocade, NetIron, OpenScript, VCS, VDX, and Vyatta are registered trademarks, and The Effortless Network and the On-Demand Data Center are trademarks of Brocade Communications Systems, Inc., in the United States and in other countries. Other brands and product names mentioned may be trademarks of others.

Notice: This document is for informational purposes only and does not set forth any warranty, expressed or implied, concerning any equipment, equipment feature, or service offered or to be offered by Brocade. Brocade reserves the right to make changes to this document at any time, without notice, and assumes no responsibility for its use. This informational document describes features that may not be currently available. Contact a Brocade sales office for information on feature and product availability. Export of technical data contained in this document may require an export license from the United States government.

The authors and Brocade Communications Systems, Inc. assume no liability or responsibility to any person or entity with respect to the accuracy of this document or any loss, cost, liability, or damages arising from the information contained herein or the computer programs that accompany it.

The product described by this document may contain open source software covered by the GNU General Public License or other open source license agreements. To find out which open source software is included in Brocade products, view the licensing terms applicable to the open source software, and obtain a copy of the programming source code, please visit <http://www.brocade.com/support/oscd>.

Brocade Communications Systems, Incorporated

Corporate and Latin American Headquarters
Brocade Communications Systems, Inc.
130 Holger Way
San Jose, CA 95134
Tel: 1-408-333-8000
Fax: 1-408-333-8101
E-mail: info@brocade.com

Asia-Pacific Headquarters
Brocade Communications Systems China HK, Ltd.
No. 1 Guanghua Road
Chao Yang District
Units 2718 and 2818
Beijing 100020, China
Tel: +8610 6588 8888
Fax: +8610 6588 9999
E-mail: china-info@brocade.com

European Headquarters
Brocade Communications Switzerland Sàrl
Centre Swissair
Tour B - 4ème étage
29, Route de l'Aéroport
Case Postale 105
CH-1215 Genève 15
Switzerland
Tel: +41 22 799 5640
Fax: +41 22 799 5641
E-mail: emea-info@brocade.com

Asia-Pacific Headquarters
Brocade Communications Systems Co., Ltd. (Shenzhen WFOE)
Citic Plaza
No. 233 Tian He Road North
Unit 1308 - 13th Floor
Guangzhou, China
Tel: +8620 3891 2000
Fax: +8620 3891 2111
E-mail: china-info@brocade.com

Document History

Title	Publication number	Summary of changes	Date
<i>FIPS Security Seal Procedures for Brocade FCX Series and Brocade FastIron SX Series</i>	53-1002119-01	New document	May 2014

In this document

This document contains the instructions for the application of FIPS-compliant tamper-evident security seals to Brocade FastIron hardware devices and includes the following sections:

- [FIPS security seals](#)
- [Preparing to apply FIPS security seals](#)
- [Applying seals to Brocade devices](#)

FIPS security seals

Each seal in the Tamper Evident Seals kit (XBR-000195) measures 1.27 cm (.5 in.) by 3.18 cm (1.25 in.) and has a unique serial number printed on it. Seals must be correctly placed on each hardware device to satisfy the requirements for FIPS 140-2 Level 2 compliance.

The seals should be stored in a room temperature environment—between 20 and 25°C (68 to 77°F). Avoid applying seals in environments where the temperature is 10°C (50°F) or less.

The seals have a shelf life of one year. After that period, new seals should be purchased.

NOTE

It is recommended that you follow your company's policy for recording the seal serial numbers used and for proper disposal of expired seals.

Once installed, if the seals are tampered with, you will be able to see the following tamper evidence:

- Appearance of a checkerboard destruct pattern
- Graphics printed within the seal can be partially visible on both the removed seal and the residue remaining on the surface
- Residue seen under ultraviolet light

Allow the adhesive on the back of each seal at least 24 hours to cure; tamper evidence might not be visible until the adhesive cures.

Preparing to apply FIPS security seals

The time to apply security seals varies by the number of seals required for a particular model. The application of seals to a Brocade FastIron or NetIron can take 10 minutes or longer.

Before beginning this task, ensure that you have the proper Tamper Evident Seals Kit (part number XBR-000195) and alcohol pads to clean the surfaces on which the seals will be affixed. Clean surfaces with alcohol and ensure that the surfaces are dry before applying security seals.

Applying seals to Brocade devices

Seal placement varies by switch model. This section includes the following FIPS seal application procedures:

- [Applying seals to Brocade FCX 624S-F, Brocade FCX 624S, and Brocade FCX 624S-HPOE](#)
- [Applying seals to Brocade FCX 648S and Brocade FCX 648S-HPOE devices](#)
- [Applying seals to Brocade FastIron SX 800 devices](#)
- [Applying seals to Brocade FastIron SX 1600 devices](#)

NOTE

The figures in this document show transparent representations of the seals to show the specific openings or fasteners that the seals are designed to cover. The actual seals are opaque.

To apply security seals, ensure that the following requirements are met:

- Carefully remove the seals from the backing and place them on the device. Do not use bare fingers to handle the labels. Using tweezers, peel away the backing slowly and carefully to avoid contaminating or disturbing the adhesive.
- When applying a seal to the device, use firm pressure across the surface of the entire seal to ensure maximum adhesion.
- Allow at least 24 hours for the adhesive to fully cure. Evidence of tampering might not be apparent until the adhesive cures.

NOTE

You should store any extra seals in a secure, temperature-controlled area.

Applying seals to Brocade FCX 624S-F, Brocade FCX 624S, and Brocade FCX 624S-HPOE

Use the figures in this section as a guide for security seal placement on the following Brocade FastIron devices:

- Brocade FCX 624S-F
- Brocade FCX 624S
- Brocade FCX 624S-HPOE

The connectors on the faceplates of your particular device might vary from the connectors shown on the figures, but the placement of the seals will be the same. [Figure 1](#) on page 5 and [Figure 2](#) on page 6 display a Brocade FCX 624S with seals as a model for the seal placement on the Brocade FCX 624S-F, Brocade FCX 624S, and Brocade FCX 624S-HPOE. Each of these devices requires the placement of 13 seals:

- **Top:** Affix 4 total seals to the top panel of the device. Affix two seals so that they cover the left and right frontmost screws on the top panel of the device. Affix two seals so that they cover the two screws adjacent to the frontmost screws on the top panel. See [Figure 1](#) for correct seal orientation and positioning.
- **Right and left sides:** Affix 4 total seals to the left and right sides of the device—two seals on the right side and two seals on the left side. Each seal should cover two holes on either side of the first vent section. See [Figure 1](#) for correct seal orientation and positioning on the right side of the device. The orientation and placement of seals on the left side mirrors the orientation and placement of seals on the right side of the device (visible in [Figure 1](#)).
- **Front:** Affix one seal horizontally-aligned with half affixed to the front panel and half affixed to the bottom panel. You must bend this seal to place it correctly. See [Figure 1](#) for correct seal orientation and positioning.

- **Rear:** Affix 4 total seals to the rear panel of the device. Affix one seal from the rear panel to the bottom panel and three seals from the rear panel to the top panel. You must bend these seals to place them correctly. See [Figure 2](#) on page 6 for correct seal orientation and positioning.

FIGURE 1 Front, top, and right side views of a Brocade FCX 624S device with security seals.

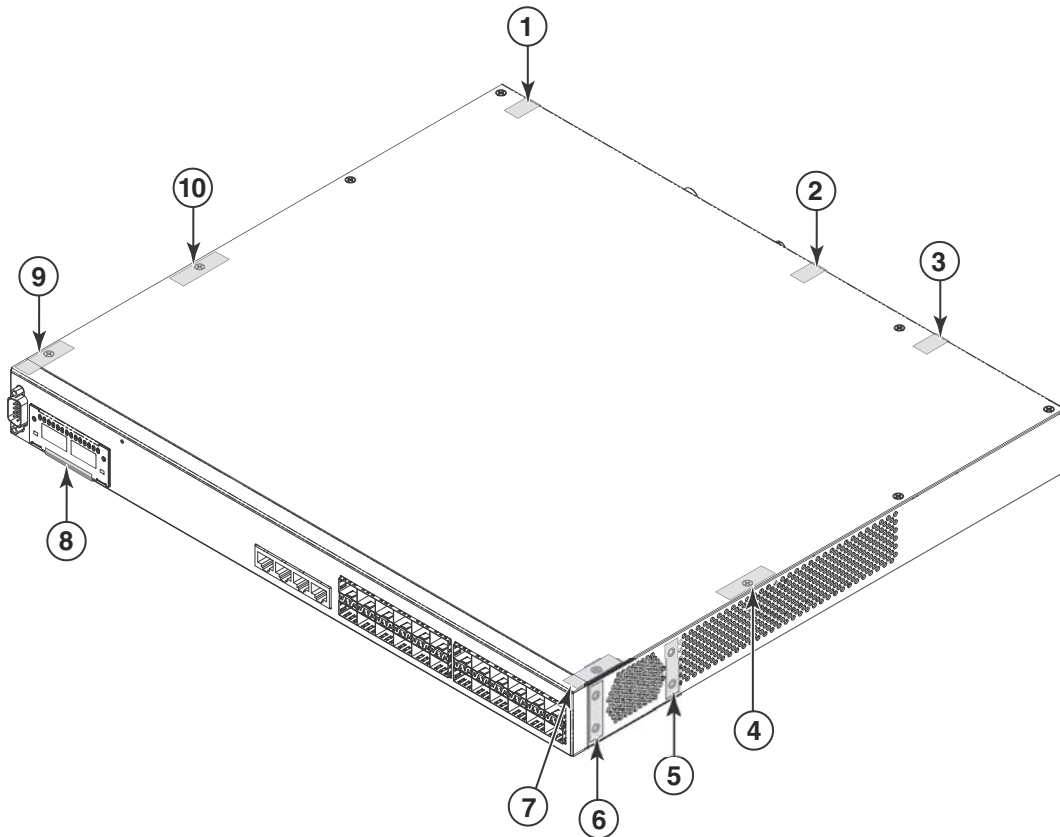

1 to 10 = FIPS security seals

NOTE

The orientation and placement of seals on the left side of the device mirrors the orientation and placement of seals on the right side of the device. Seal placement on the right side of the device is visible in [Figure 1](#) above and [Figure 2](#) on page 6.

FIGURE 2 Rear, bottom, and left side views of a FCX 624S device with security seals

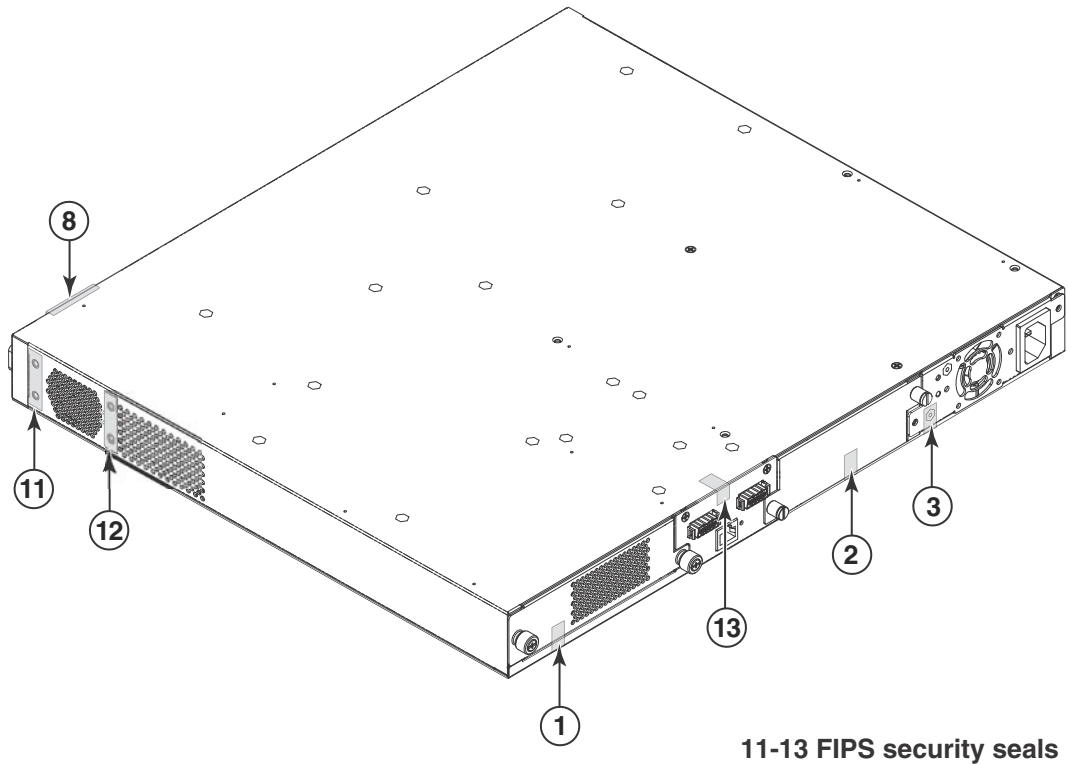

Applying seals to Brocade FCX 648S and Brocade FCX 648S-HPOE devices

Use the figures in this section as a guide for security seal placement on the following Brocade FastIron devices:

- Brocade FCX 648S
- Brocade FCX 648S-HPOE

The connectors on the faceplates of your particular device might vary from the connectors shown on the figures, but the placement of the seals will be the same. [Figure 3](#) on page 7 and [Figure 4](#) on page 8 display a Brocade FCX 648S with seals as a model for the seal placement on the Brocade FCX 648S and Brocade FCX 648S-HPOE. Each of these devices requires the placement of 13 seals:

- **Top:** Affix 4 total seals to the top panel of the device. Affix two seals so that they cover the left and right frontmost screws on the top panel of the device. Affix two seals so that they cover the two screws adjacent to the frontmost screws on the top panel. See [Figure 3](#) for correct seal orientation and positioning.
- **Right and left sides:** Affix 4 total seals to the left and right sides of the device—two seals on the right side and two seals on the left side. Each seal should cover two holes on either side of the first vent section. See [Figure 3](#) for correct seal orientation and positioning on the right side of the device. The orientation and placement of seals on the left side mirrors the orientation and placement of seals on the right side of the device (visible in [Figure 3](#)).
- **Front:** Affix one seal horizontally-aligned with half affixed to the front panel and half affixed to the bottom panel. You must bend this seal to place it correctly. See [Figure 3](#) for correct seal orientation and positioning.

- **Rear:** Affix 4 total seals to the rear panel of the device. Affix one seal from the rear panel to the bottom panel and three seals from the rear panel to the top panel. You must bend these seals to place them correctly. See [Figure 4](#) on page 8 for correct seal orientation and position.

FIGURE 3 Front, top, and right side views of a Brocade FCX 648S device with security seals.

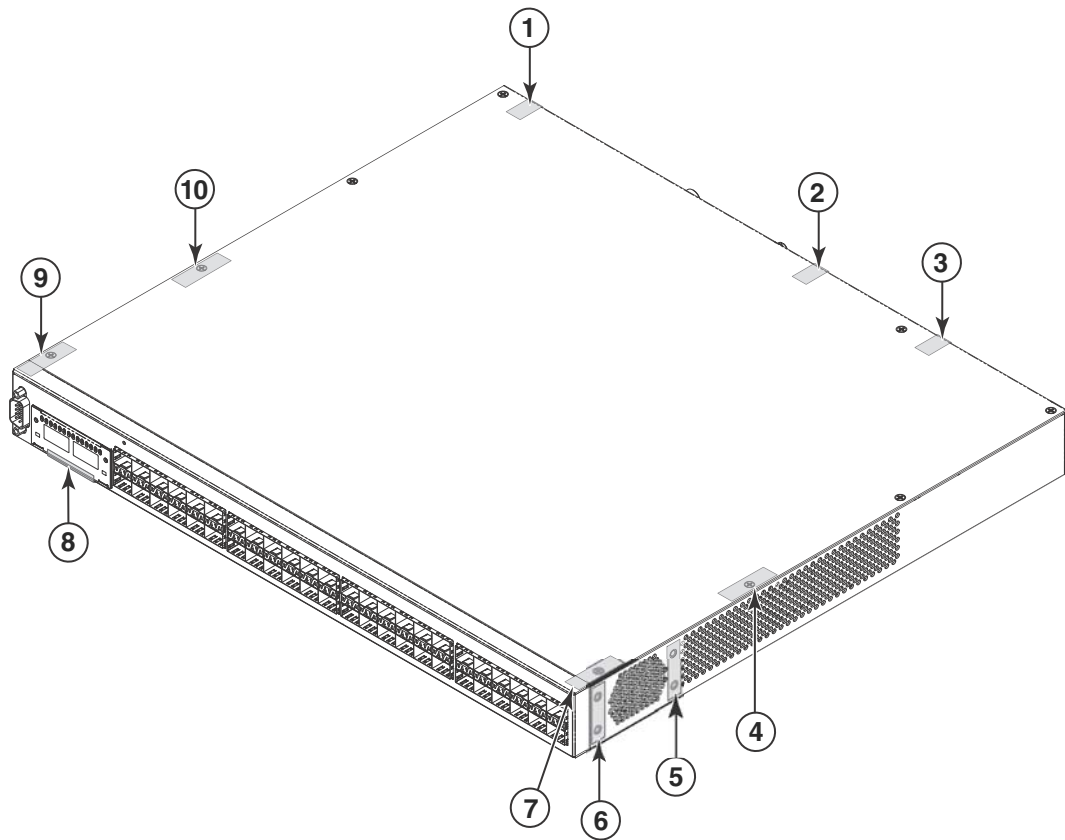

1 to 10 = FIPS security seals

NOTE

The orientation and placement of seals on the left side of the device mirrors the orientation and placement of seals on the right side of the device. Seal placement on the right side of the device is visible in [Figure 3](#) above and [Figure 4](#) on page 8.

FIGURE 4 Rear, bottom, and left side views of a FCX 648S device with security seals

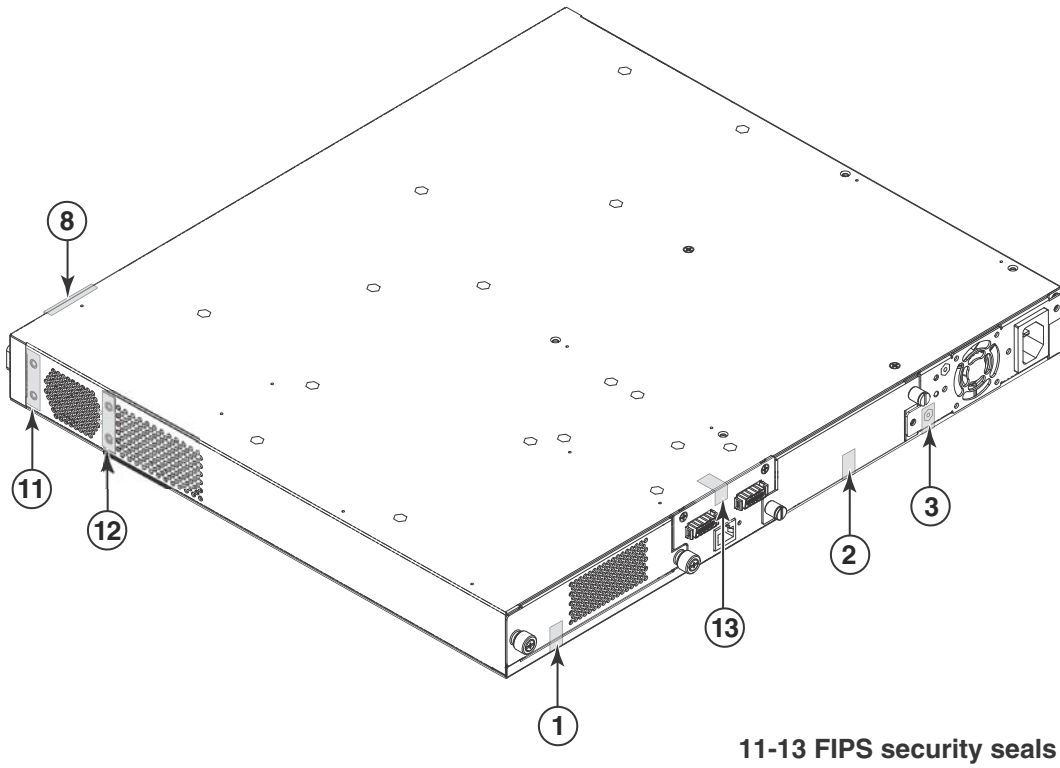

Applying seals to Brocade FastIron SX 800 devices

Use the figures in this section as a guide for security seal placement on a Brocade FastIron SX 800 device.

The connectors on the faceplates of a particular module might vary from the connectors shown on the figures, but the placement of the seals will be the same. There is no seal placement required on the side panels or solely on the top and bottom panels of Brocade FastIron SX 800 devices. Each Brocade FastIron SX 800 device requires the placement of 16 seals:

- **Front:** Affix 15 total seals to the front panel of the device. Affix one vertically-oriented seal to the left ear of each module installed in the left side of the chassis. As much as possible of the seal should be affixed to the module directly above the left screw for the left side modules. Affix one vertically-oriented seal to each of the modules installed in the right side of the chassis by affixing the seals directly under the screw to the right ear of each module and to the chassis. Affix one seal from the upper right corner of the fan tray to the chassis. All 15 of these seals should lie flat against the front of the device. See [Figure 5](#) for correct seal orientation and positioning.

FIGURE 5 Front view of a Brocade FastIron SX 800 device with security seals

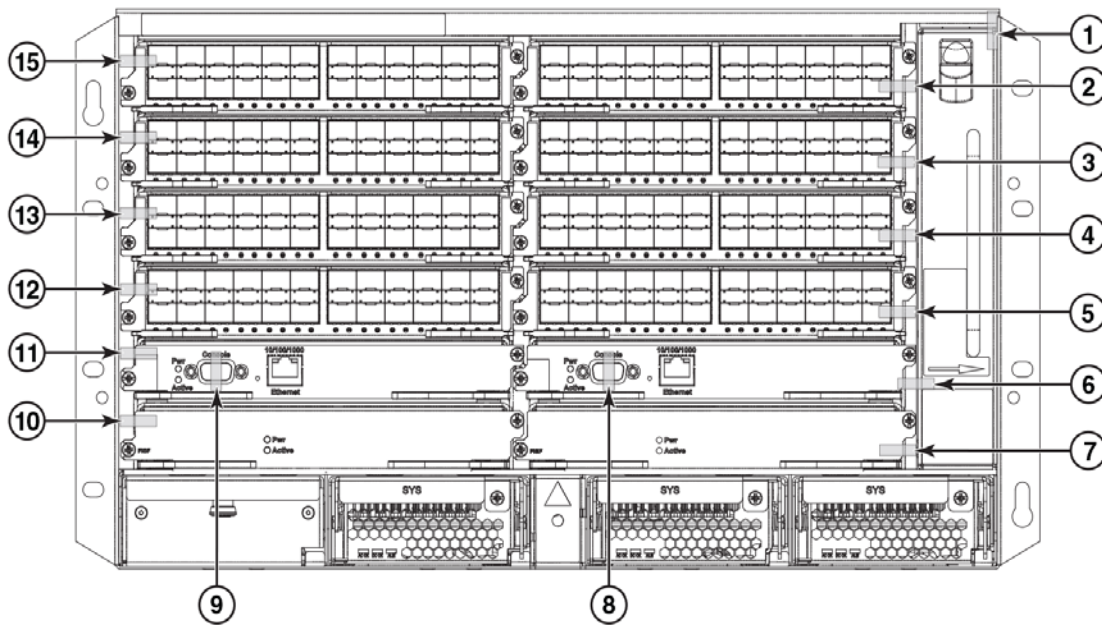

1 to 15 = FIPS security seals

- Rear:** Affix 3 total seals to the rear panel of the device. Affix two vertically-aligned seals at the upper right and left sides of the rear panel so that one half of the seal is affixed to the top panel of the device and the other half is affixed to the rear panel and covering the rightmost and leftmost screws. You must bend these seals to place them correctly. Affix one seal vertically-aligned at the lower center of the rear panel so that one half of the seal is affixed to the bottom panel of the device and the other half of the seal is affixed to the rear panel of the device, covering the middle screw. See [Figure 6](#) for seal orientation and positioning.

FIGURE 6 Rear, top, and left side panel views of a Brocade FastIron SX 800 device with security seals

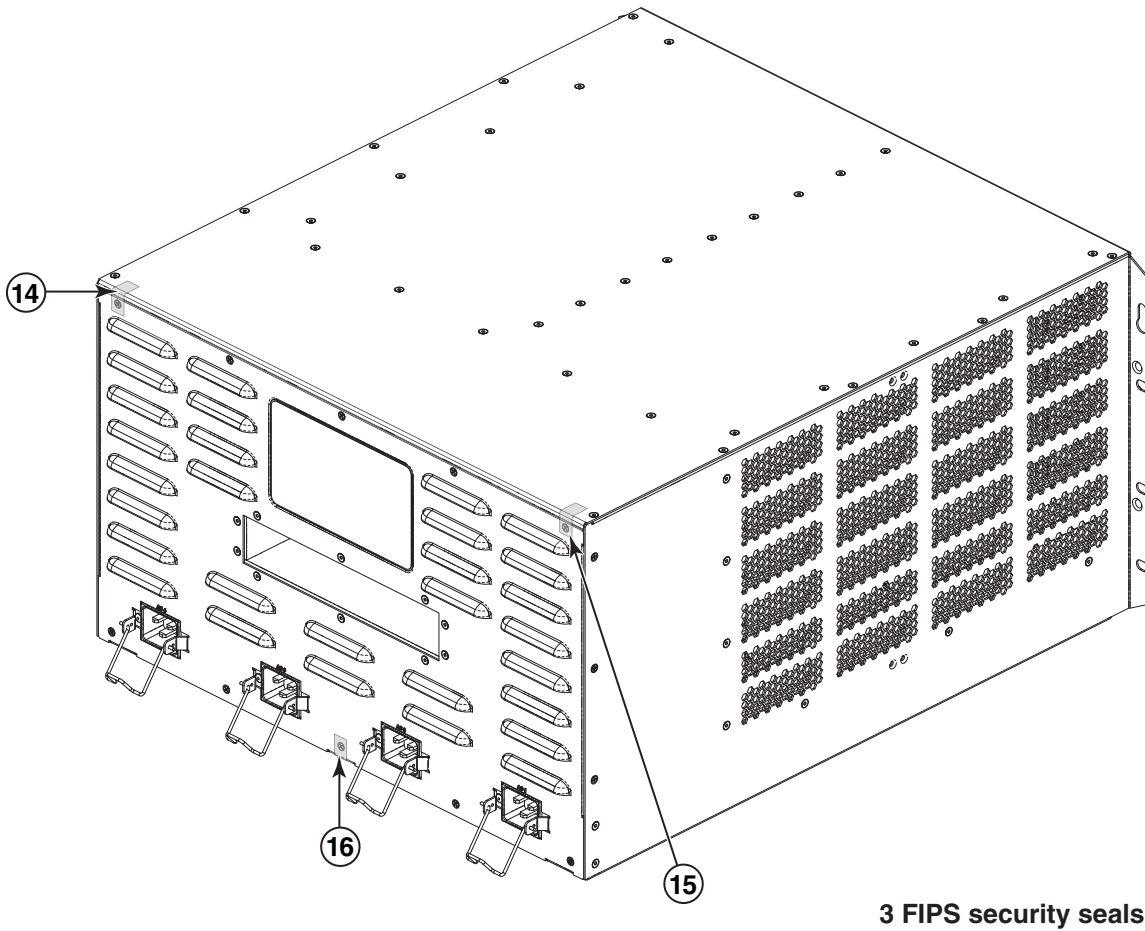

Applying seals to Brocade FastIron SX 1600 devices

Use the figures in this section as a guide for security seal placement on a Brocade FastIron SX 1600 device.

The connectors on the faceplates of a particular module might vary from the connectors shown on the figures, but the placement of the seals will be the same. There is no seal placement required on the top panel, bottom panel, or side panels of Brocade FastIron SX 1600 devices. Each Brocade FastIron SX 1600 device requires the placement of 24 seals:

- **Front:** Affix 21 total seals to the front panel of the device. Affix one horizontally-oriented seal to the upper ear of each module installed in the top row of the chassis as shown in [Figure 7](#) on page 12. As much as possible of the seal should be affixed to the module to the right of the screw that secures each module to the chassis. Affix one horizontally-oriented seal to the lower ear of each module installed in the bottom row of the chassis as shown in [Figure 7](#). As much as possible of the seal should be affixed to the module to the left of the screw that secures each module to the chassis. Affix one seal from the upper left corner of the fan tray to the chassis, as shown in [Figure 7](#). All 21 of the seals should lie flat against the front panel of the device.

FIGURE 7 Front view of a Brocade FastIron SX 1600 device with security seals

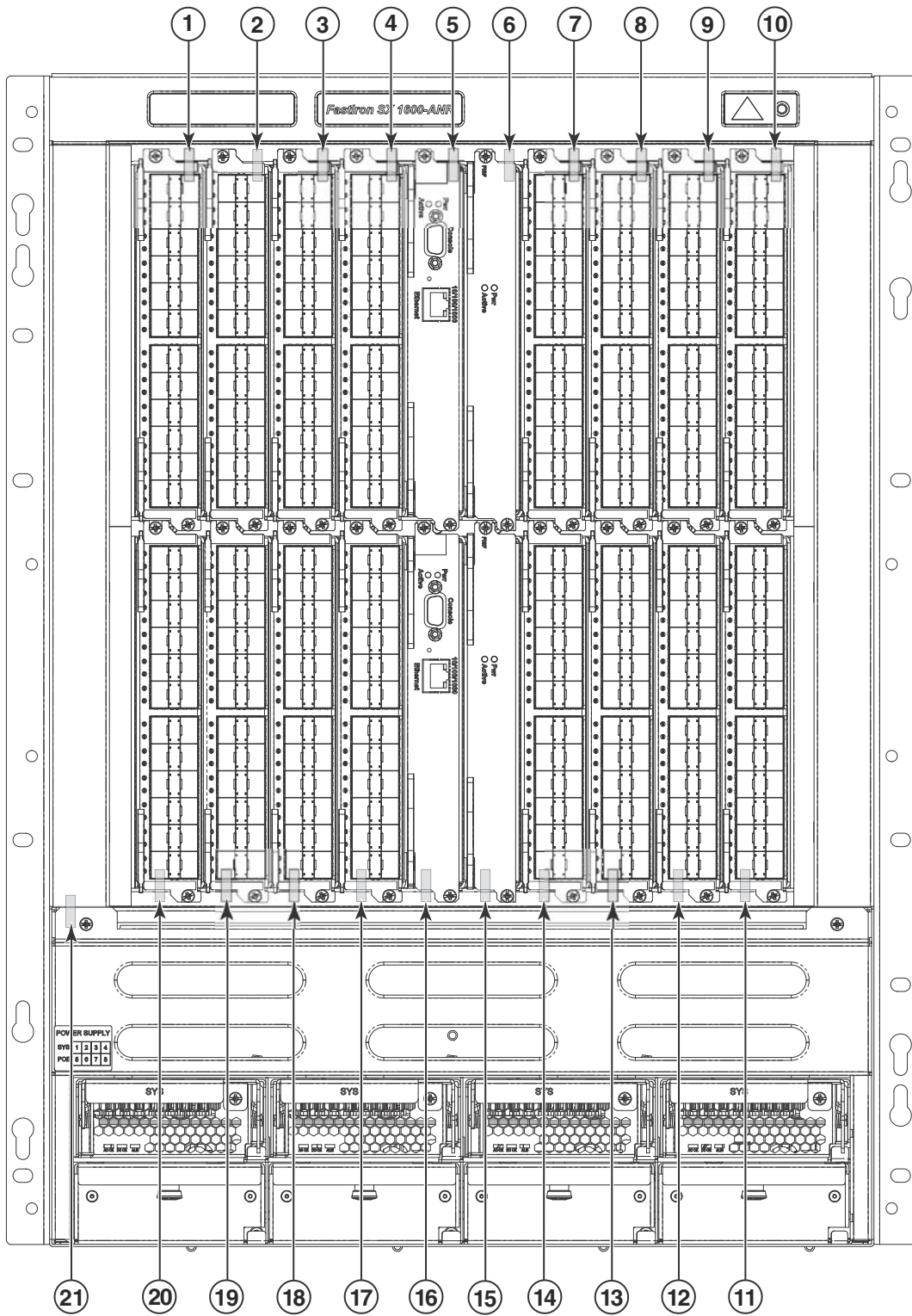

1 to 21 = FIPS security seals

- Rear:** Affix 3 total seals to the rear panel of the device. Affix two vertically-aligned seals to the right and left top edges of the chassis so that half of the seal is affixed to the top panel and half to the rear panel or, in the case of an ANR, to the bracket that attaches the ANR bracket to the rear panel of the chassis. Affix one seal vertically to the center bottom edge of the rear panel so that one half of the seal is affixed to the rear panel of the device and one half of the seal is affixed to the bottom panel. You must bend this seal to place it correctly. See [Figure 8](#) for correct seal orientation and positioning.

FIGURE 8 Rear view of the FastIron SX 1600 device (ANR version shown) with security seals

